

## IN OUT DRIVE WOOD

Sistem de uși glisante cu sină inferioară

Opritor

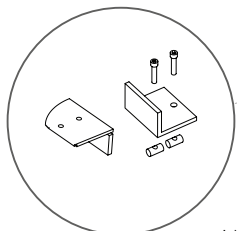

Lățime ușă

|             |       |
|-------------|-------|
| SAS 540.200 | 36 mm |
| SAS 540.290 | 25 mm |

Set de accesorii pentru  
oprirea ușii într-o direcție.

Opritor capăt

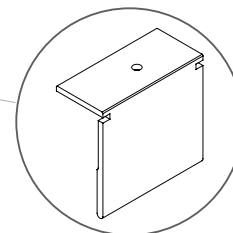

Lățime ușă

|             |       |
|-------------|-------|
| SAS 540.101 | 36 mm |
|-------------|-------|

(OPȚIONAL)

Role superioare

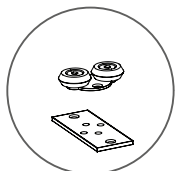

SAS 530.060.12

Set de câte 2 role  
pentru 1 ușă

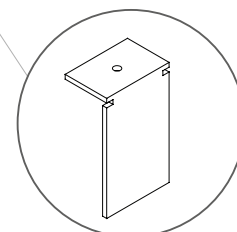

Lățime ușă

|             |       |
|-------------|-------|
| SAS 540.190 | 25 mm |
|-------------|-------|

(OPȚIONAL)

Role inferioare

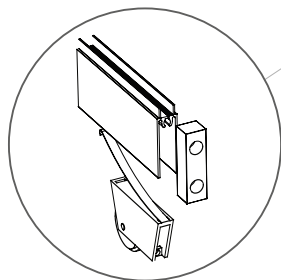

SAS 530.130.12

Set de câte 2 role  
pentru 1 ușă

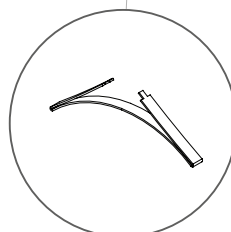

SAS 540.100

Element frânare  
Instalare pe șina inferioară

Profil de acoperire

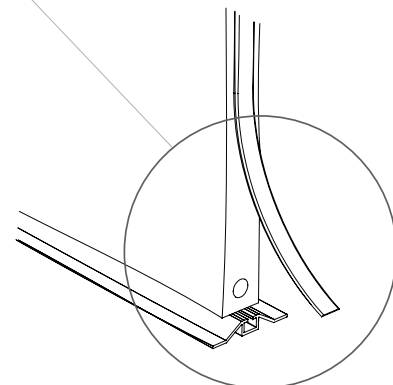

SAS 520.300.11

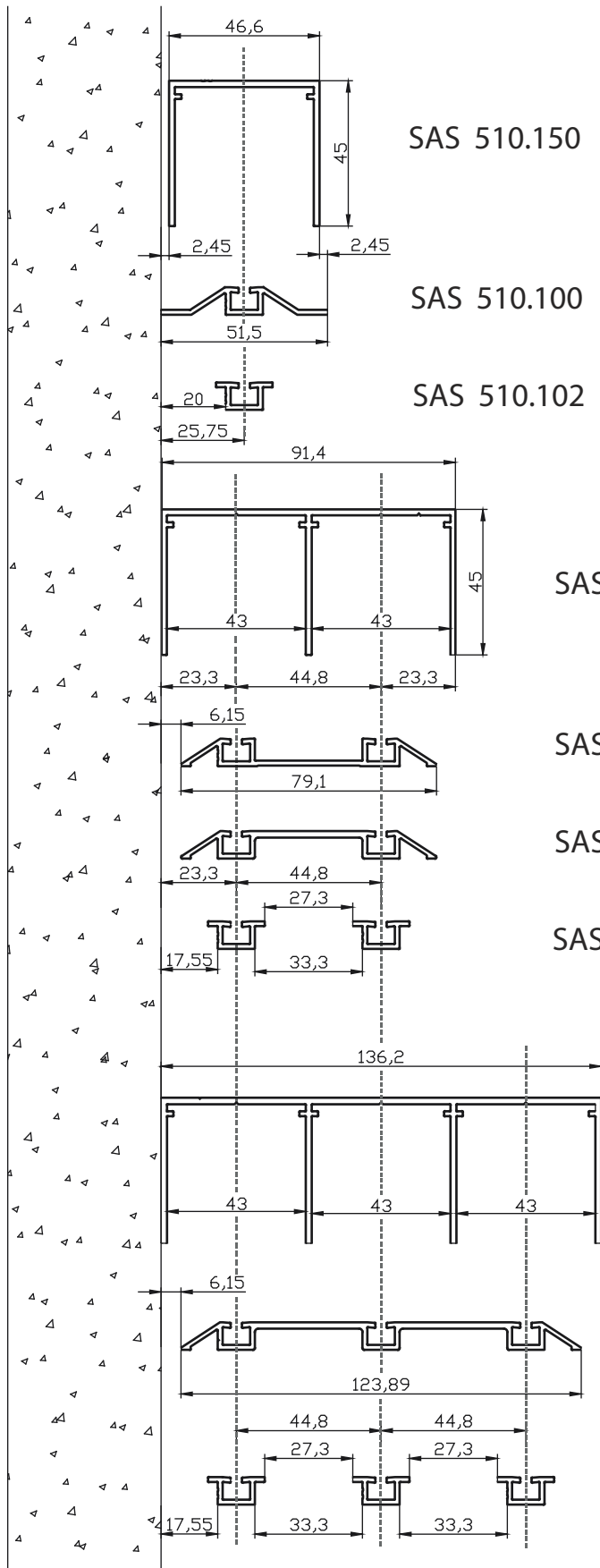

Profil horizontal inferior

SAS 510.300

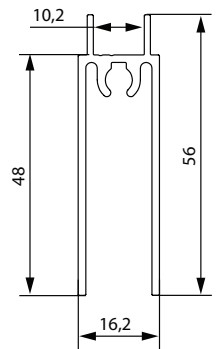

**Lemn cu grosimea de 25 mm**

**Prindere de tavan**

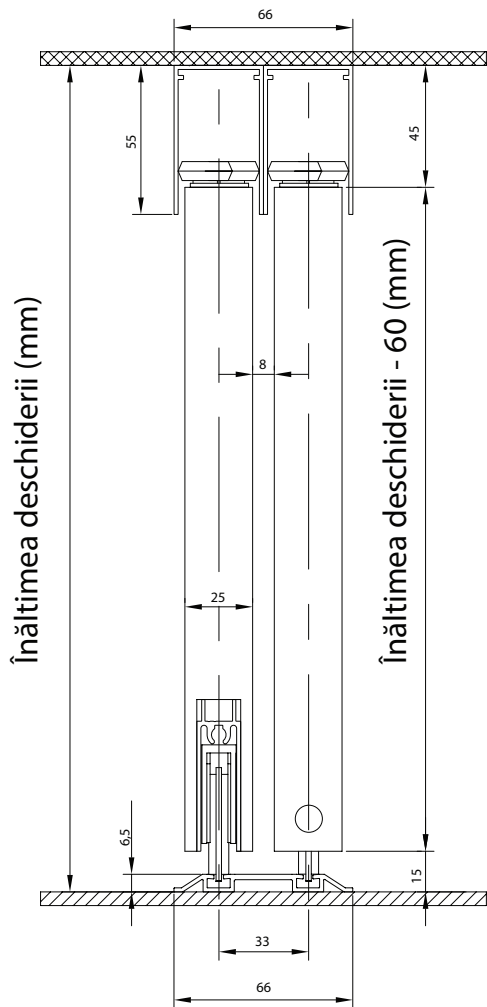

**Prindere de perete**

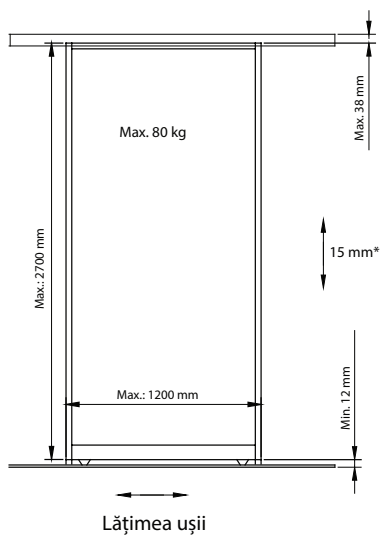
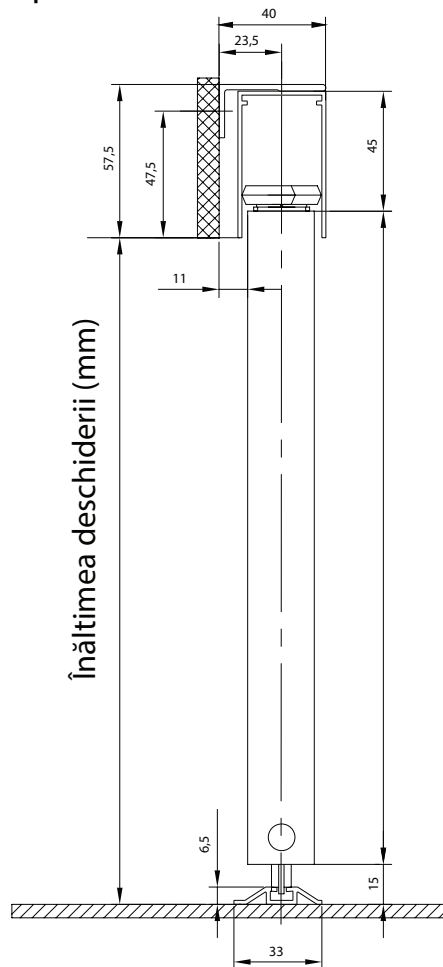

Reglarea pe înălțime a ușii  
cu soft close: 5 mm  
fără soft close: 15 mm

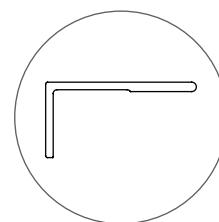

**SAS 6116**

Profil pentru prinderea de perete

**Lemn cu grosimea de 36 mm**

**Prindere de tavan**

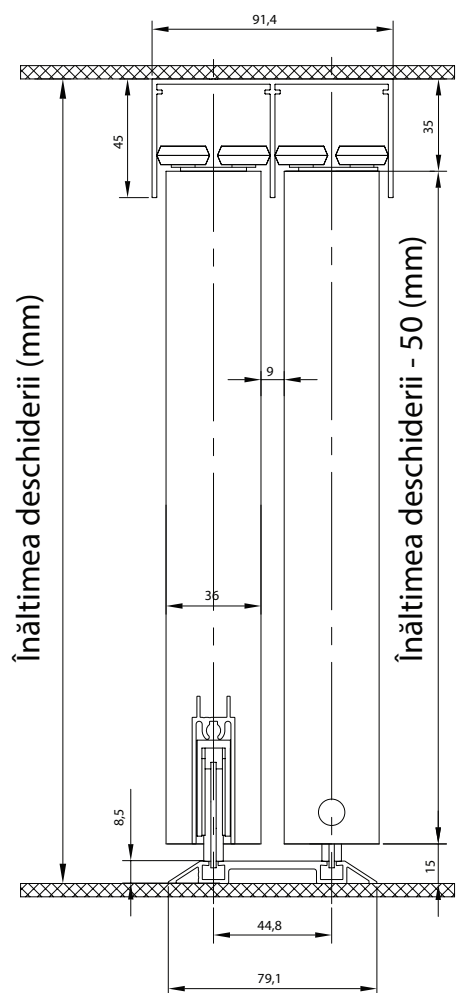

Înălțimea deschiderii (mm)

Înălțimea deschiderii - 50 (mm)

**Prindere de perete**

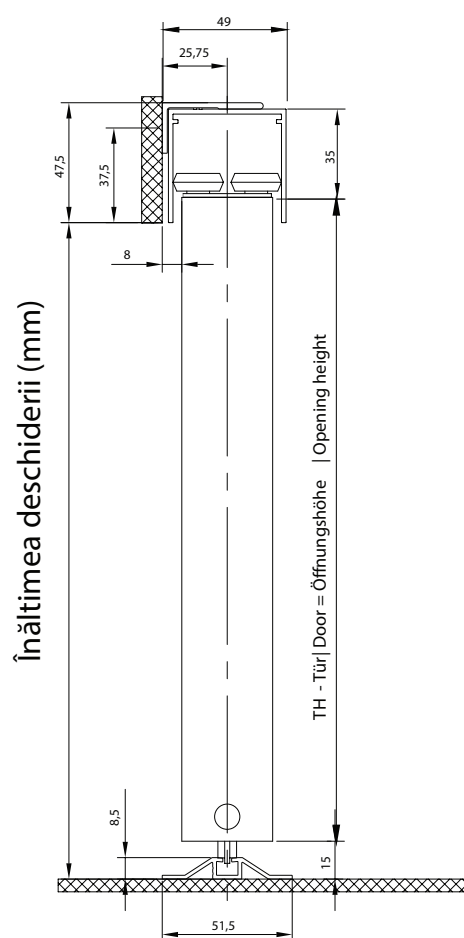

Înălțimea deschiderii (mm)

TH - Tür | Door = Öffnungshöhe | Opening height

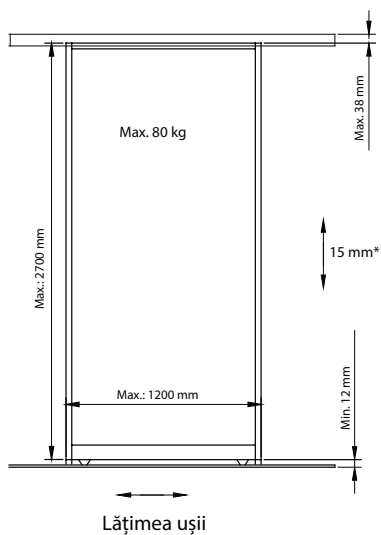

Lățimea ușii

Reglarea pe înălțime a ușii  
cu soft close: 5 mm  
fără soft close: 15 mm

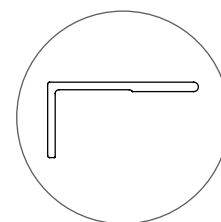

SAS 6116

Profil pentru prindere de perete

SAS 530.060.12

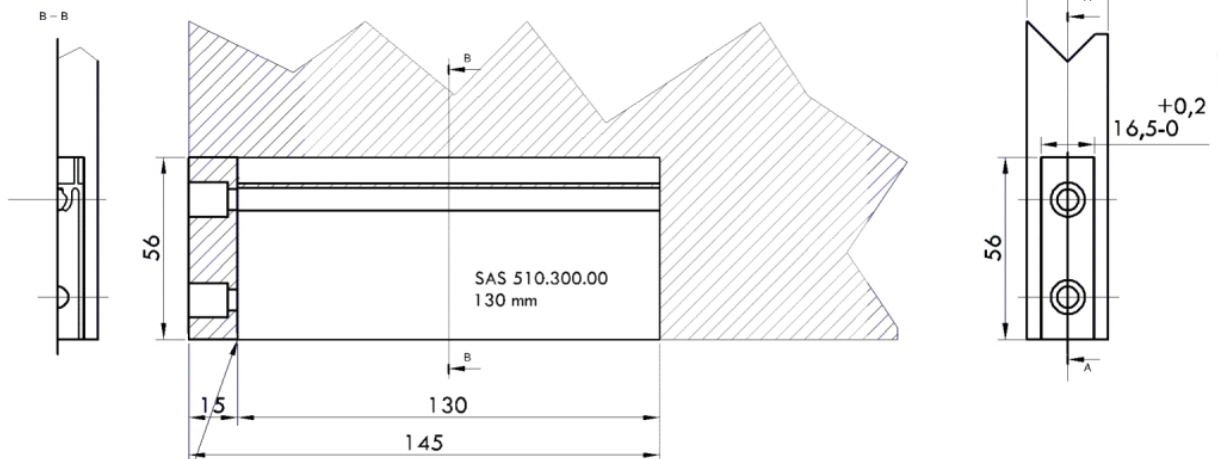
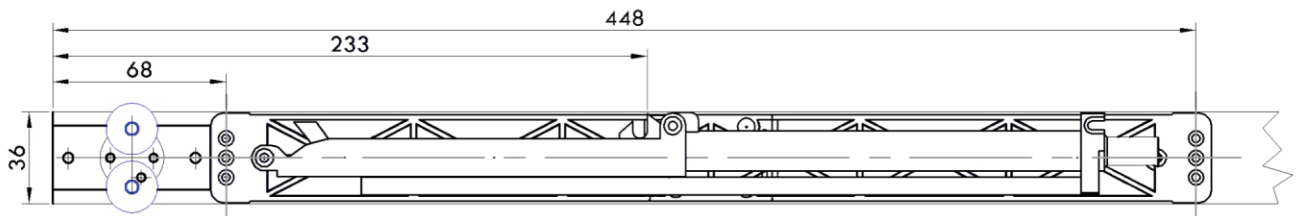
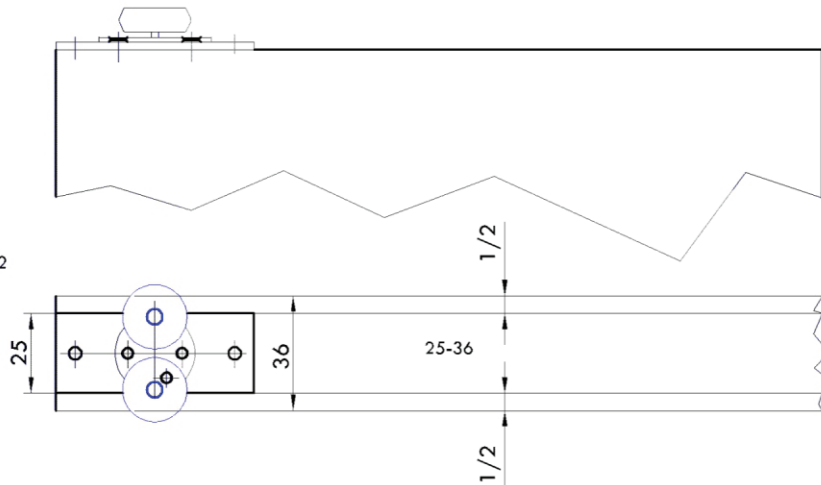

SAS 530.130.12 Set

