

## GLISIERE SERIA F10

Componente set:

1. Glisieră extragere totală și sistem push
2. Cleme prindere front
3. Bară de sincronizare

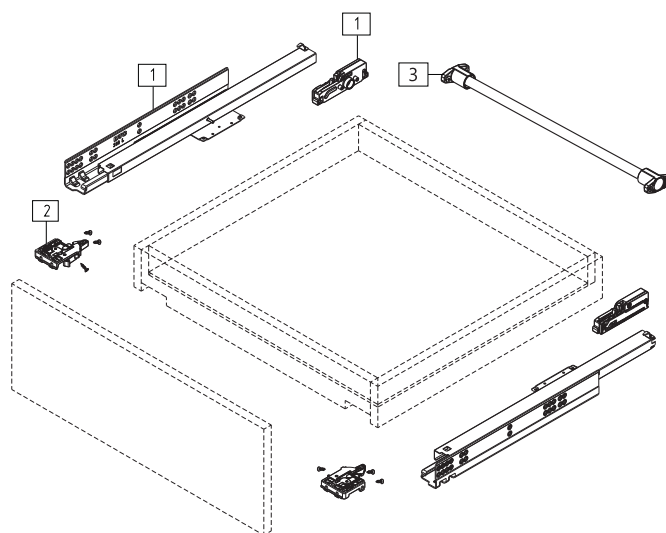

### Cote de montaj sertar standard

NL=Lungime nominală LT=Adâncime internă corp  $LT=NL+3$

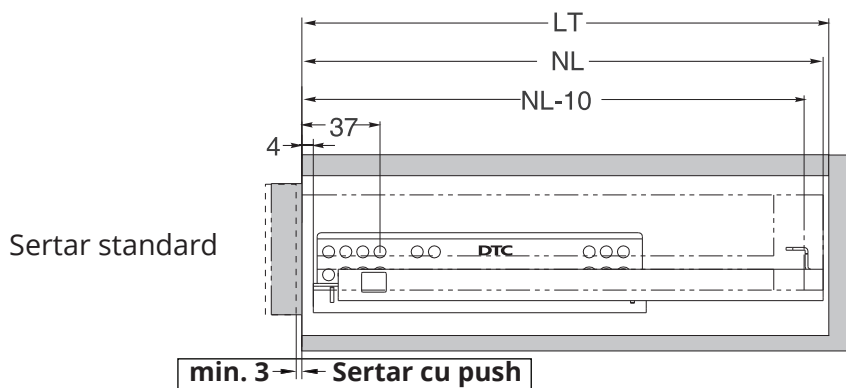

### Cote de montaj sertar intern

NL=Lungime nominală LT=Adâncime internă corp  $LT=NL+21$

