

LUNCH

Masă retractabilă

MODEL:

411/78.1105.22E - LUNCH 450
411/78.1100.22E - LUNCH 600
411/78.1110.22E - LUNCH 900
411/78.1120.22E - LUNCH 1200

INCLUDE ÎN PACHET:

- GLISIERE
- MÂNER

ACCESORII:

- A. Imbus n °5 (x 1)
B. Imbus n °4 (x 1)
C. Piuliță M6 (x 12)
D. Șurub M6x12 (x 8)
E. Șurub M6x60 (x 4)

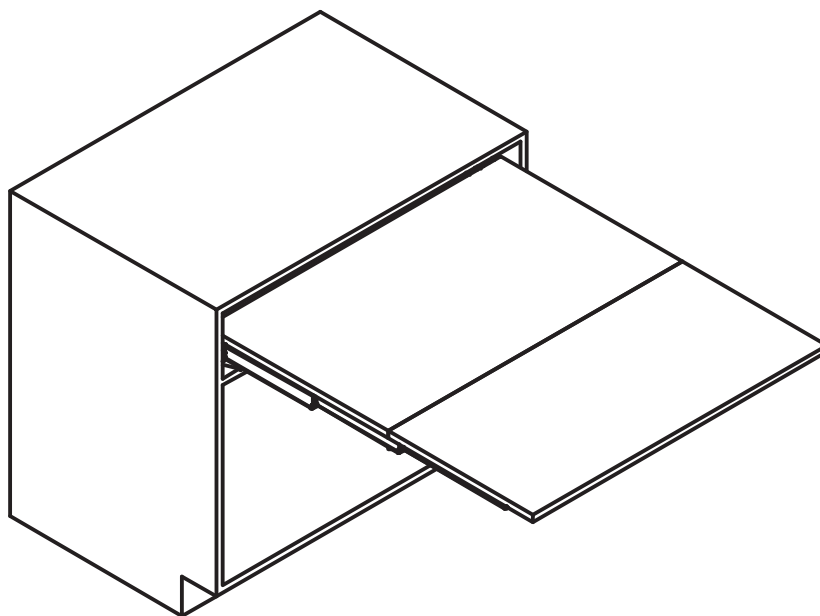

DIMENSIUNI GENERALE:

DIMENSIUNI	SIMBOL	mm
ÎNĂLȚIME	H	MIN: 120
ADÂNCIME	P	MIN: 540
LĂȚIME	L	MIN: 410 MAX: 1170
GROSIME	S	MIN: 16
GROSIMEA MARGINILOR	S1	15-20
LĂȚIMEA BLATULUI	Z	L-5
EXTRAGEREA BLATULUI	E	895

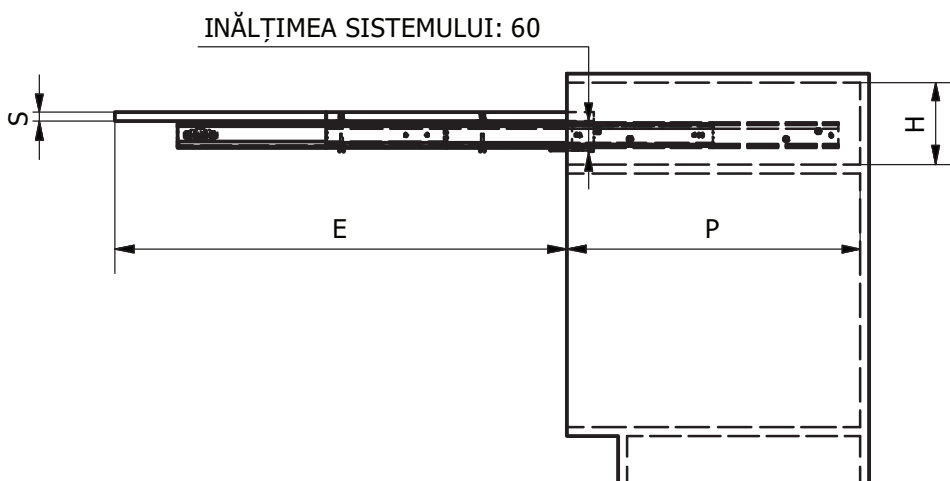

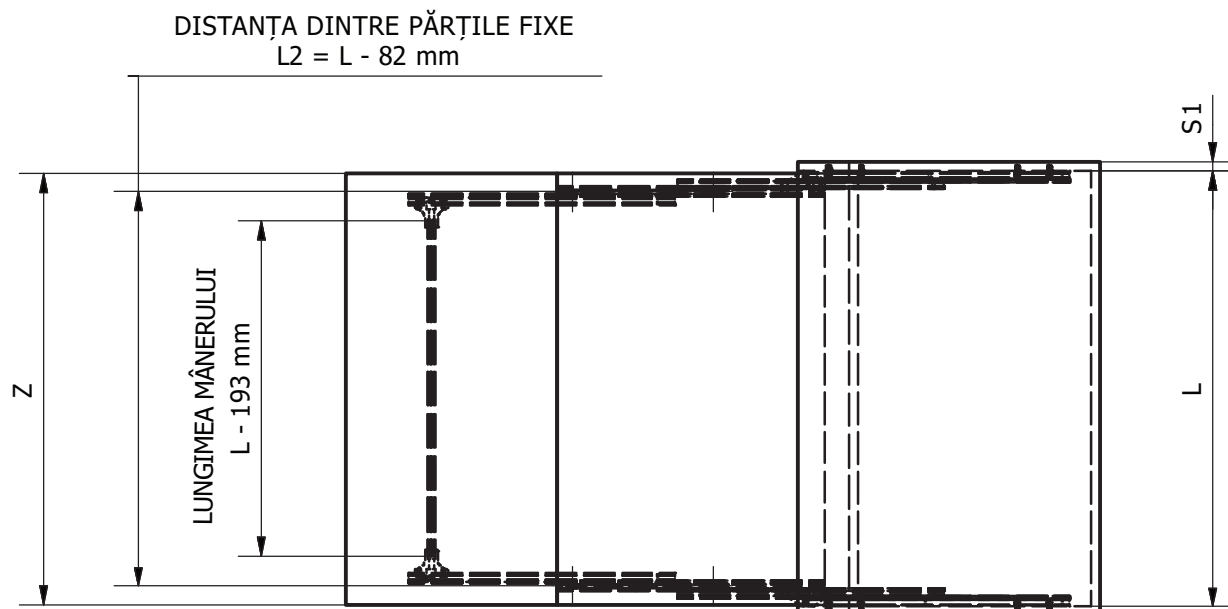

POZIȚIA GĂURILOR:

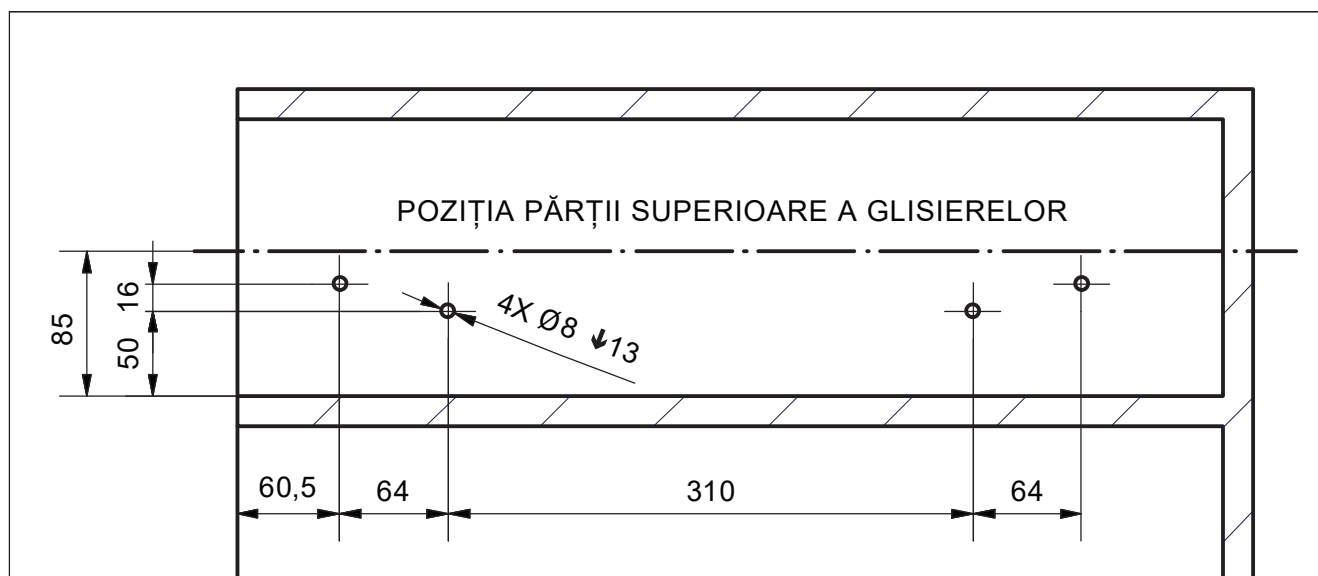

DIMENSIUNEA BLATULUI:

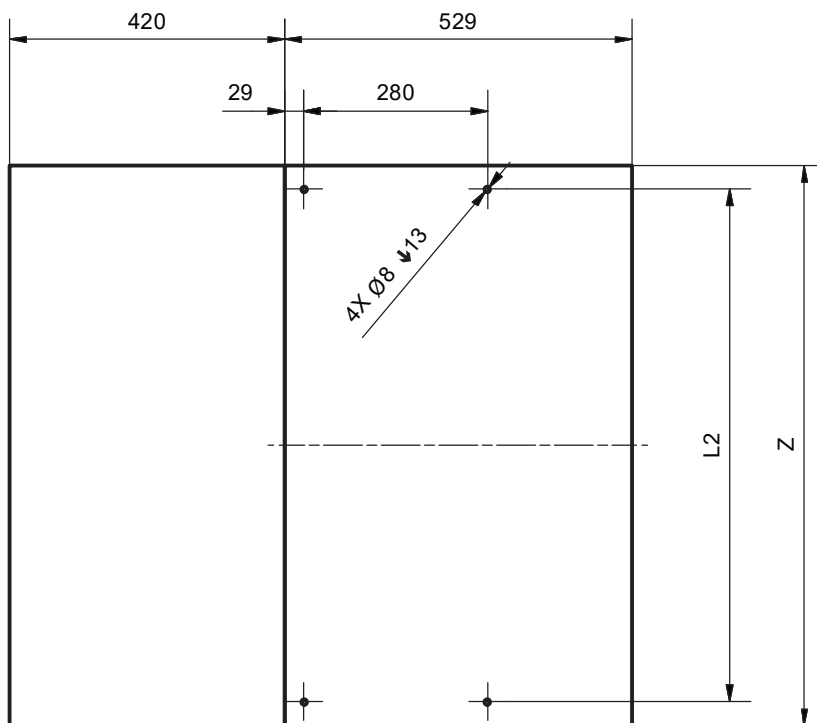

MONTAREA MECANISMULUI:

1

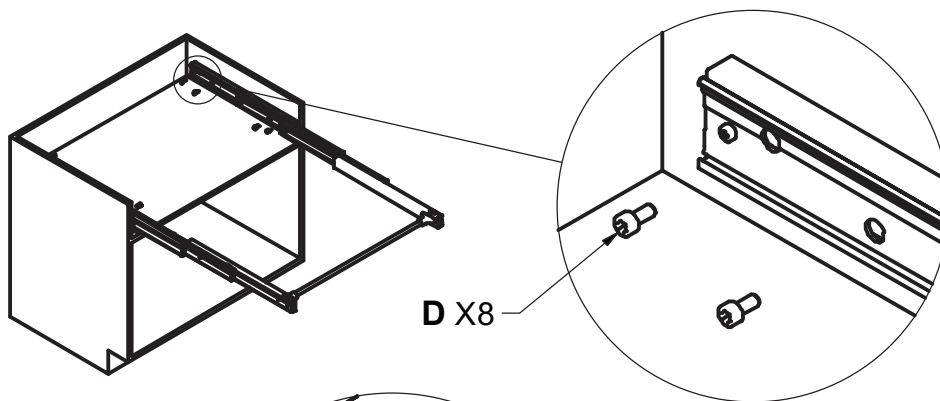

2

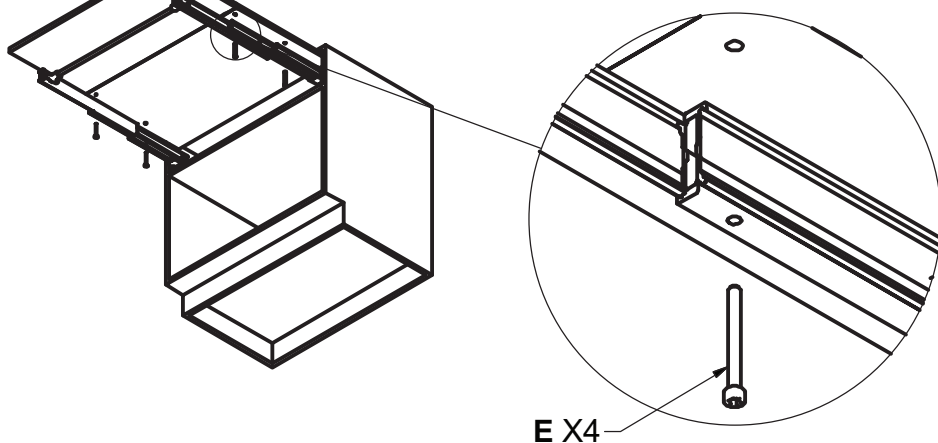

PAȘI DE UTILIZARE:

1

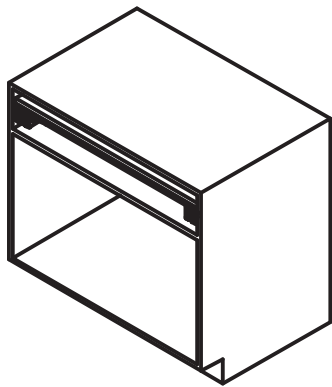

ÎNCHIS

2

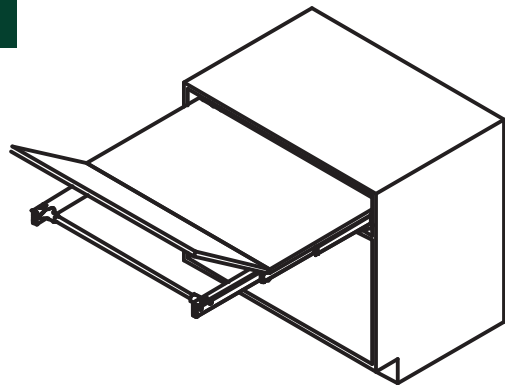

3

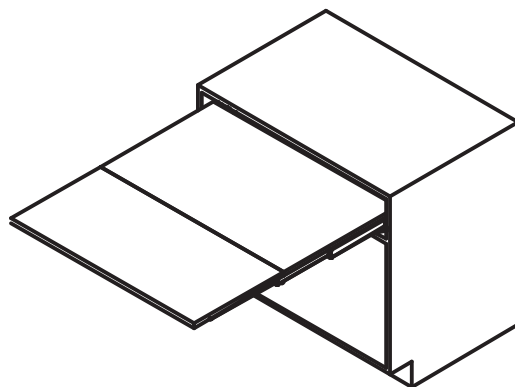

DESCHIS