

29 MARTIE 2023



ACCESORIA GROUP

INSTRUCȚIUNI MONTAJ

ART. 363PRO



- A - Coș Art. 363PRO
- B - Tipar de găurire
- C - Plăcuță rotativă

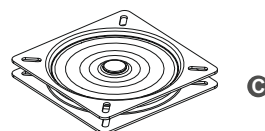
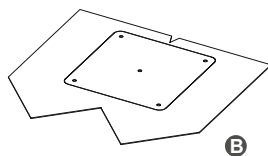
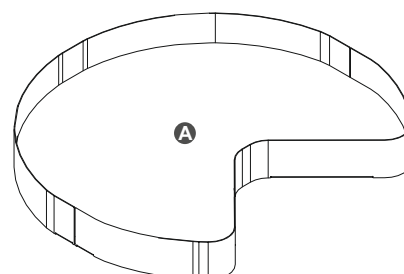
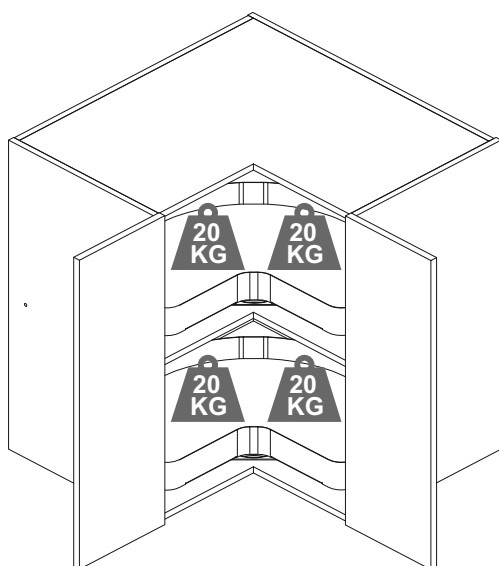
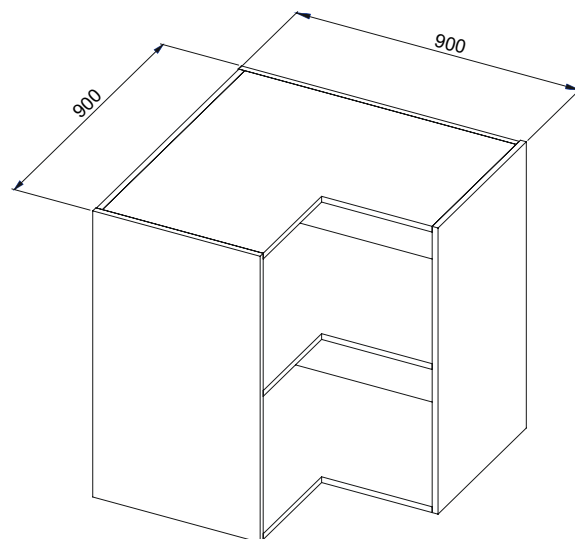

1

Fixați plăcuța rotativă C pe spatele coșului cu ajutorul șuruburilor.

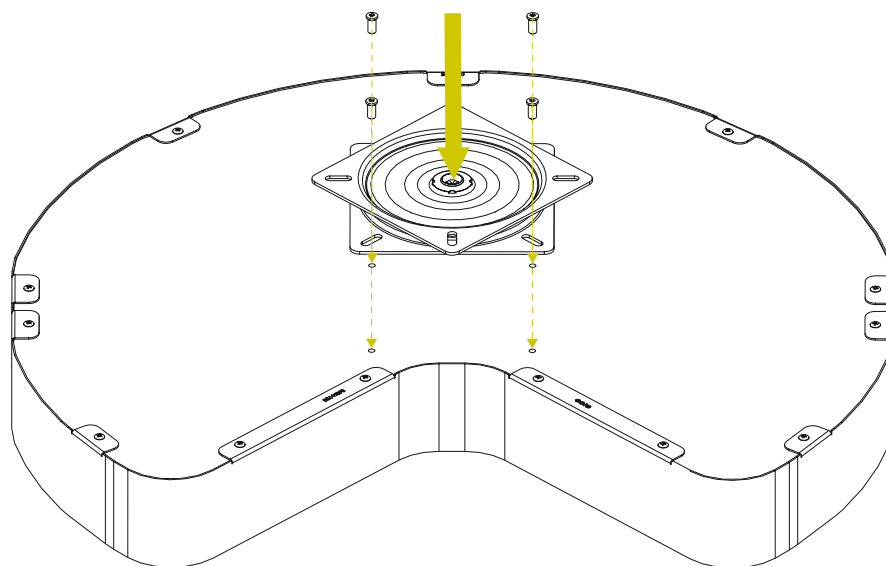

N°4 6,3x14



2

Puneți ghidajul de foraj B pe raft și găuriți cu un burghiu de 5mm la o adâncime de 12 mm.

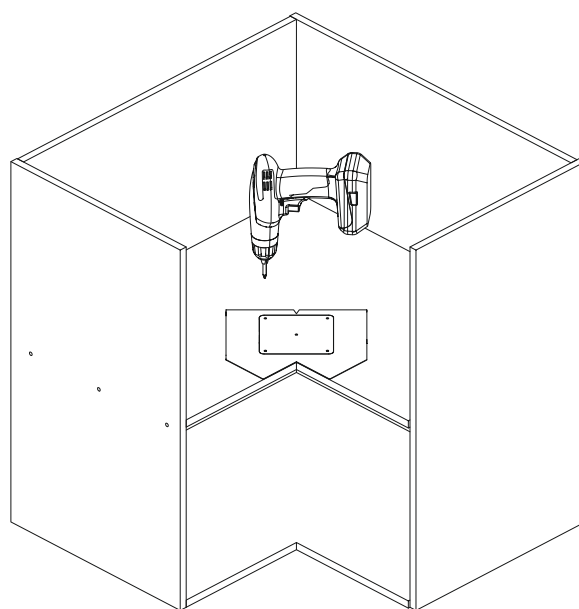
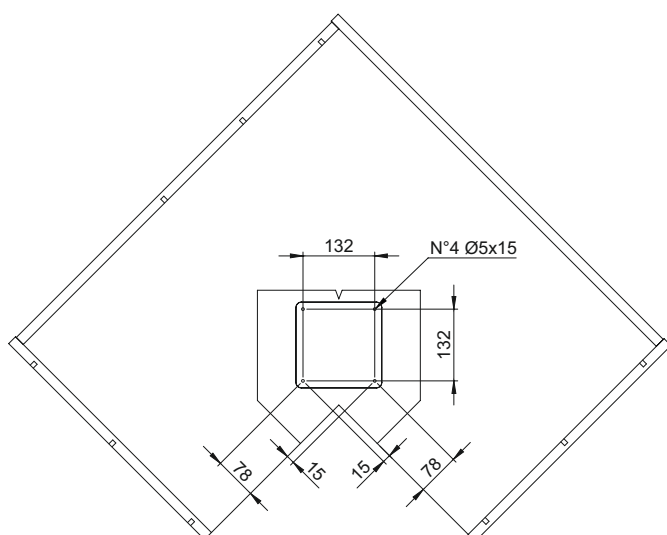

3

Amplasați coșul rotativ în corpul de mobilier.

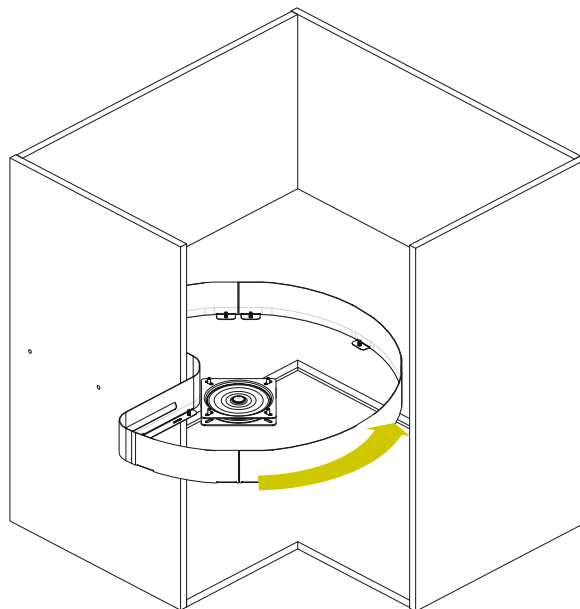

4

Înșurubați plăcuța rotativă pe raft întorcând coșul ca în imaginea de mai jos.

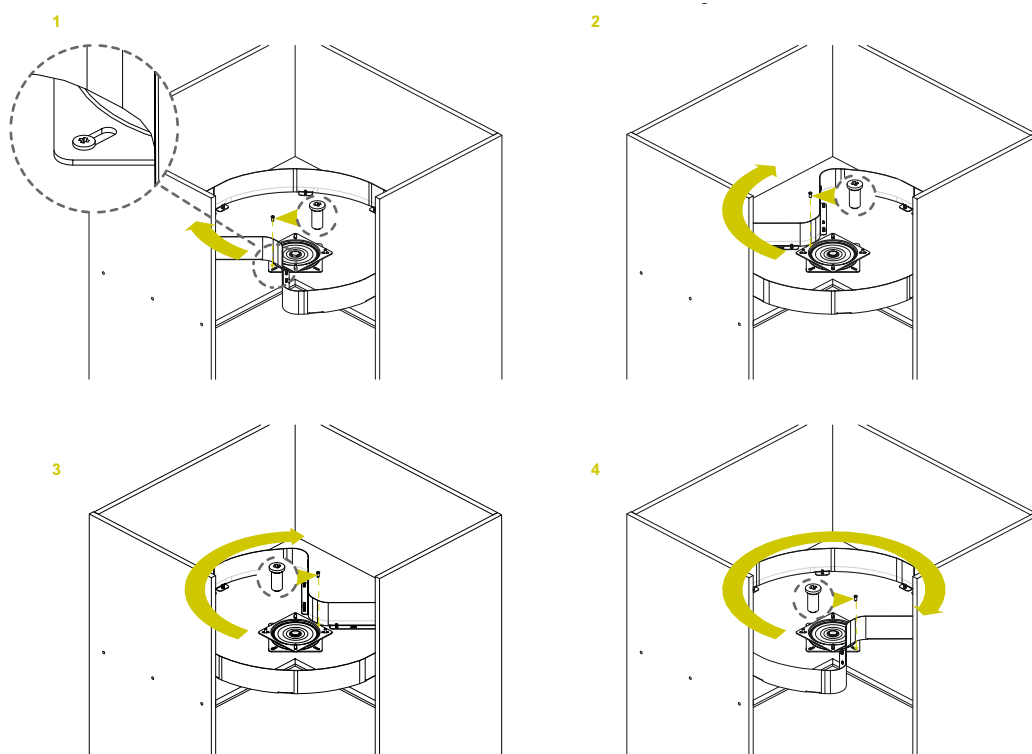

5

Montați ușa corpului de mobilier.

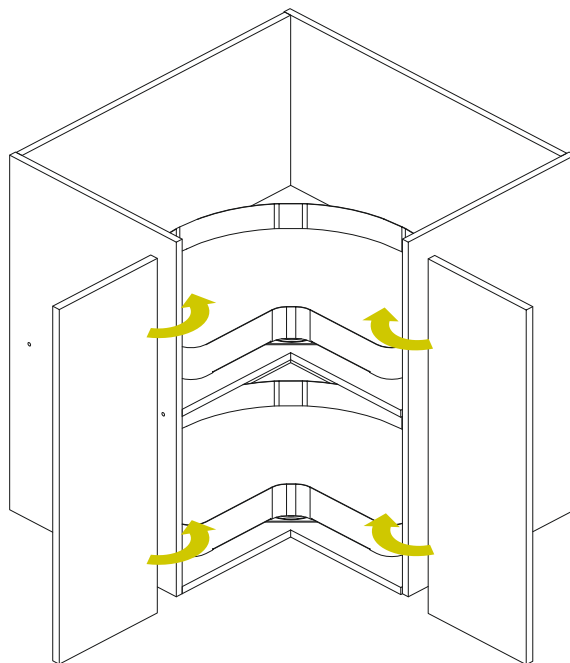

6

Pentru montarea celui de-al doilea coș, urmați aceiași pași.

