

i Tipar de găurire (mm)

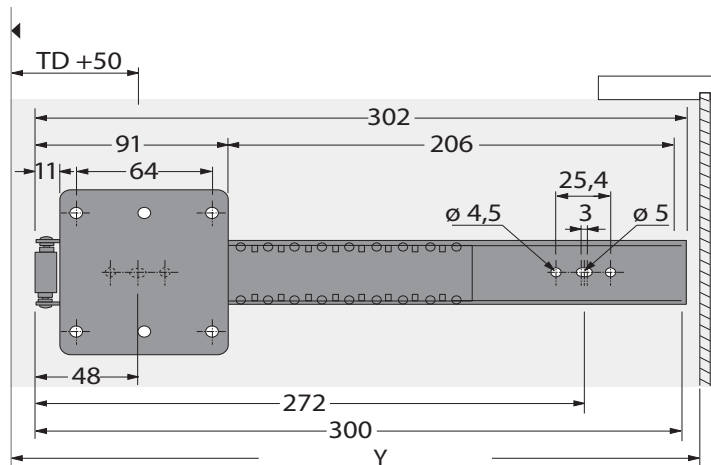

KA 5740/ **300**

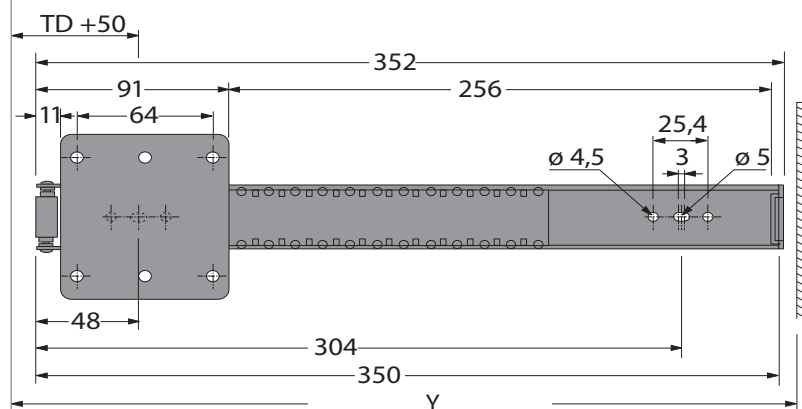

KA 5740/ **350**

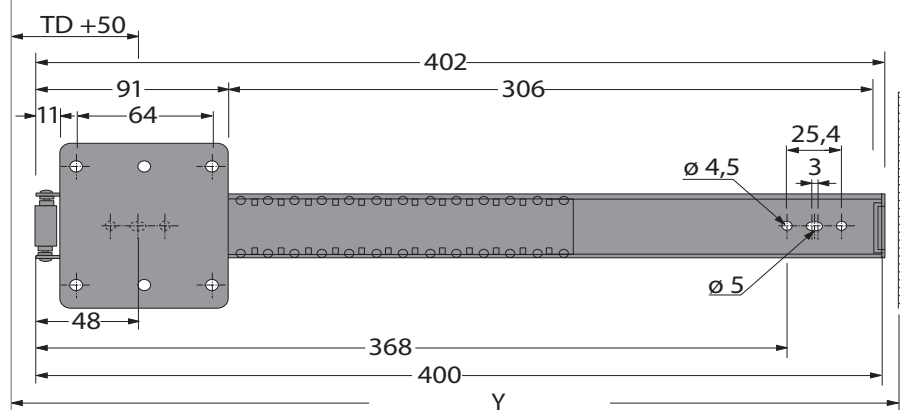

KA 5740/ **400**

Y = Adâncimea minimă a corpului

i Tipar de găurire (mm)

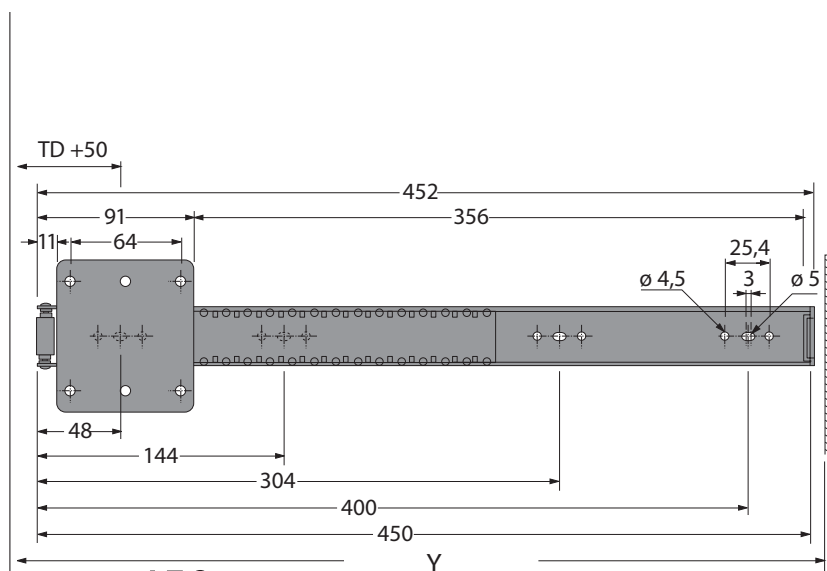

KA 5740/ **450**

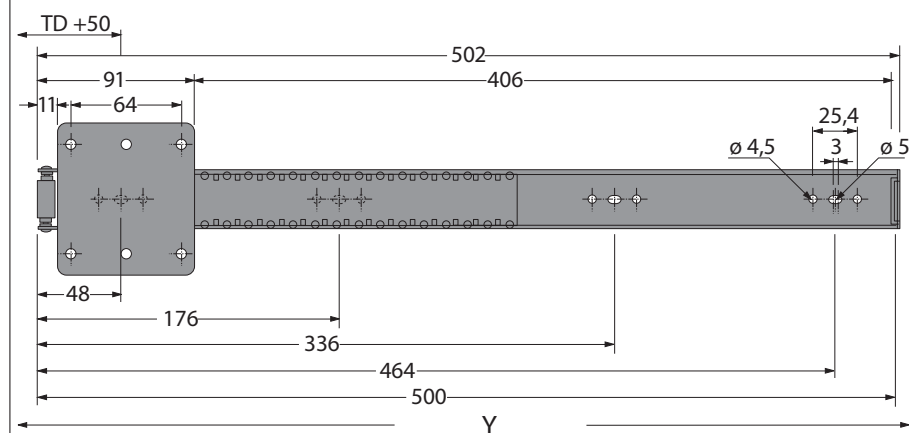

KA 5740/ **500**

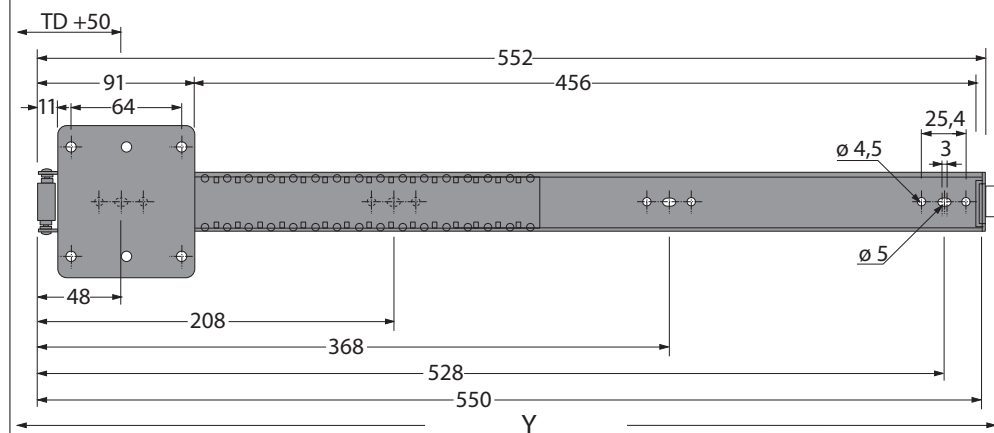

KA 5740/ **550**

Y = Adâncimea minimă a corpului

i Tipar de găurire (mm)

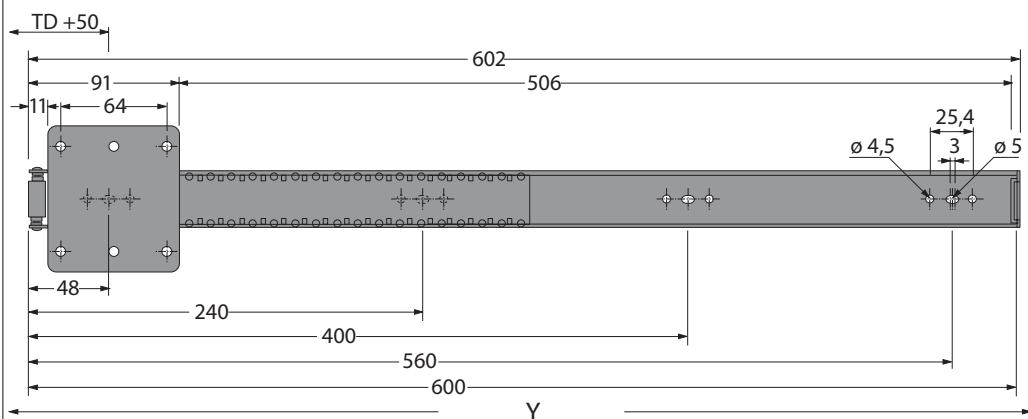

KA 5740/ **600**

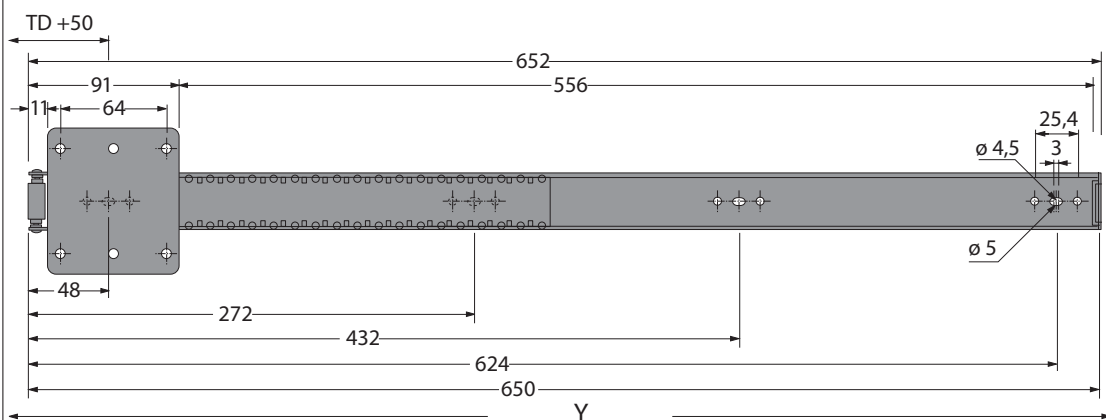

KA 5740/ **650**

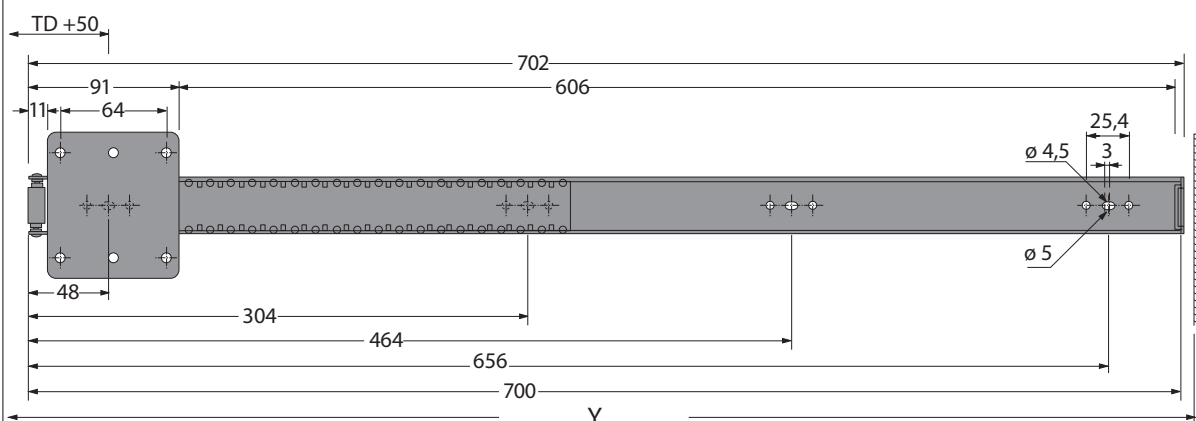

KA 5740/ **700**

Y = Adâncimea minimă a corpului

i Tăiere și asamblare

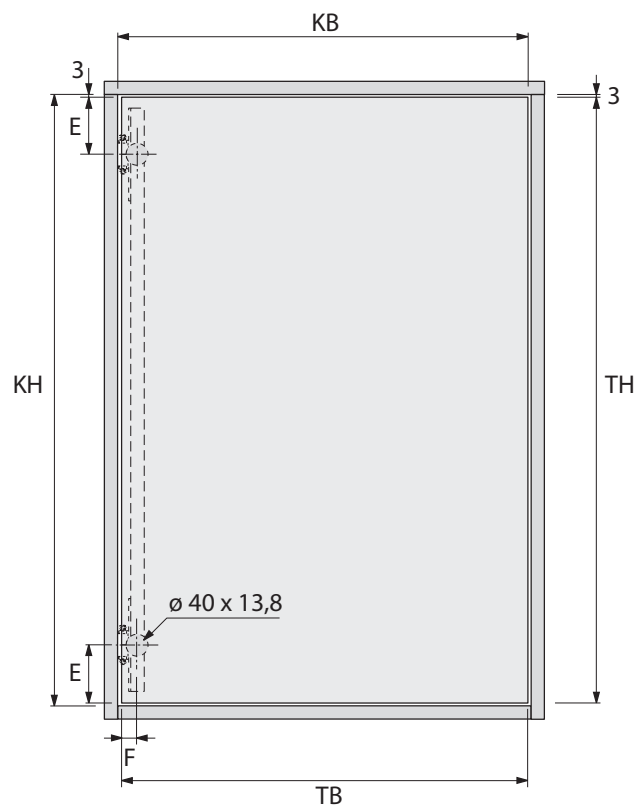
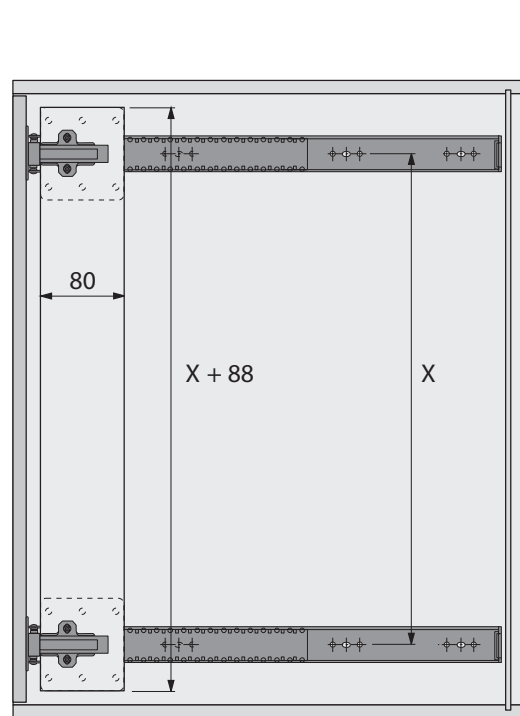

TD

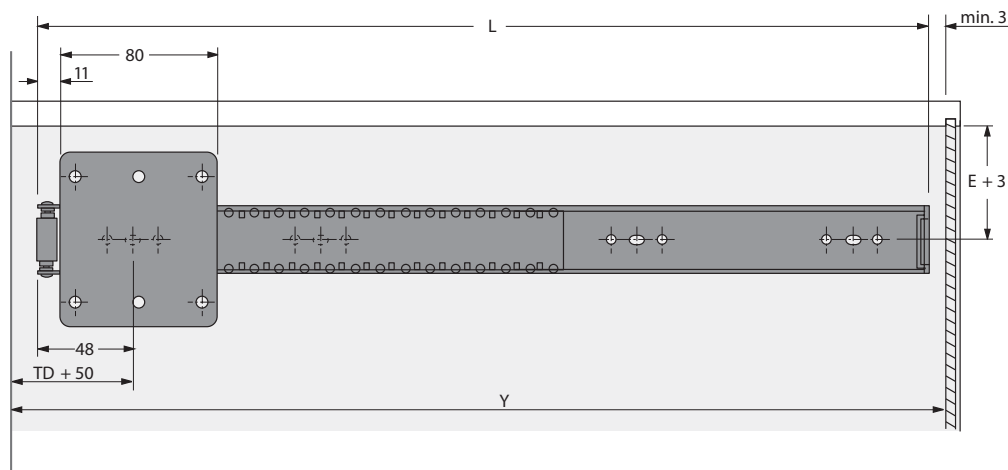
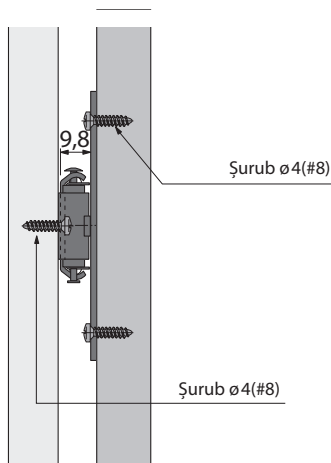

E	min. 60 mm
TH	KH - 2 x 3 mm (TH max. 900 mm)
X	TH - 2E
TB	KB - 2 x 3 mm
Y	L + (TD + 2 mm) + min. 3 mm

i

Aplicația 1 (Plăci 12 mm)

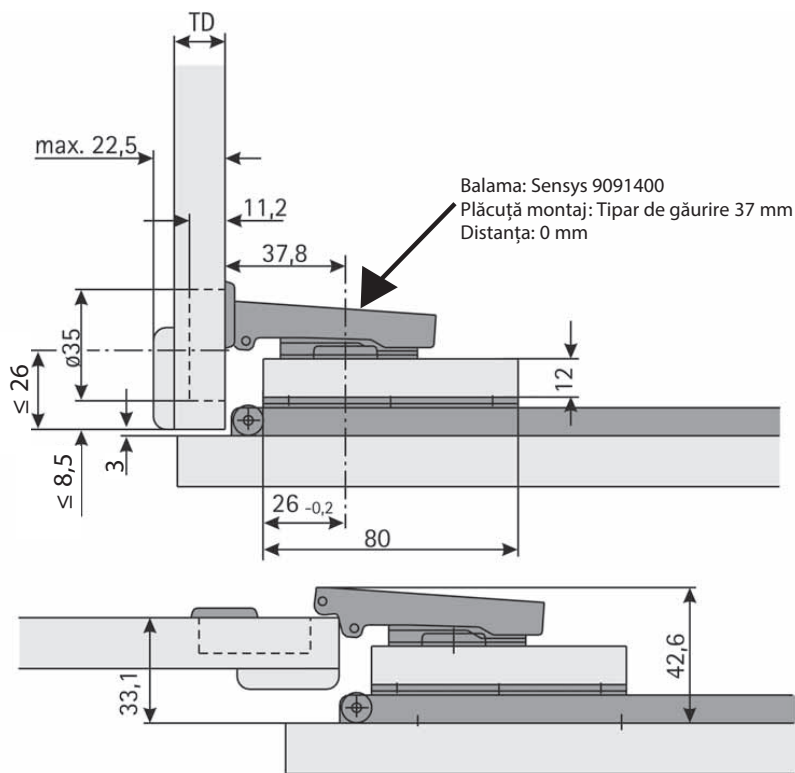

i

Aplicația 2 (Plăci 16 -21 mm)

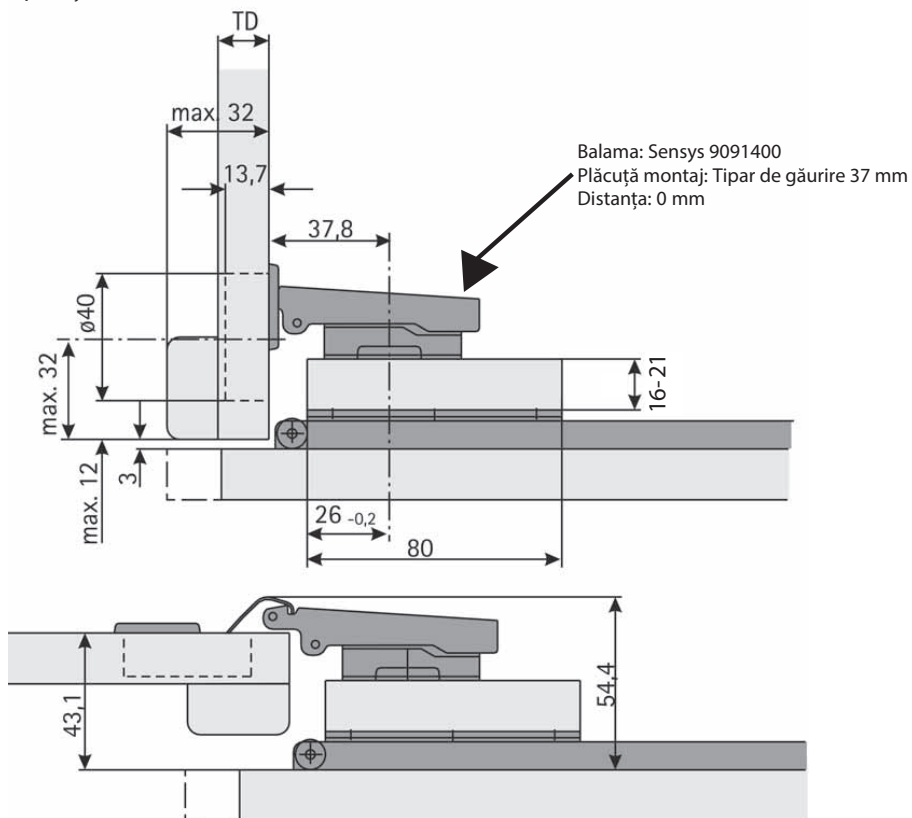

i Pași de asamblare

1

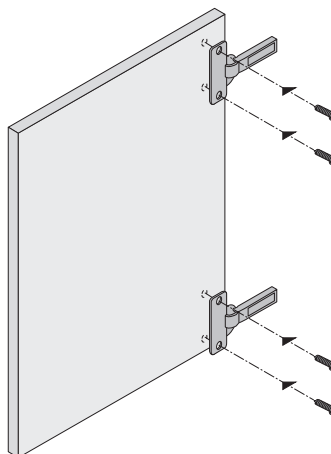

2

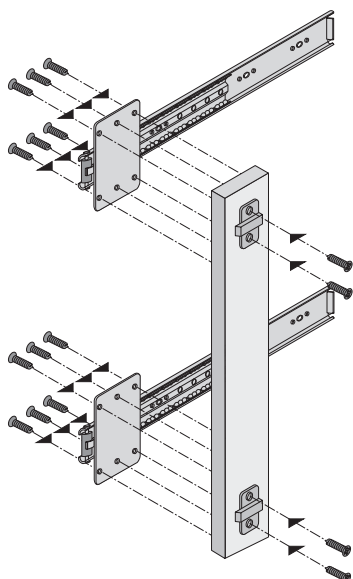

3

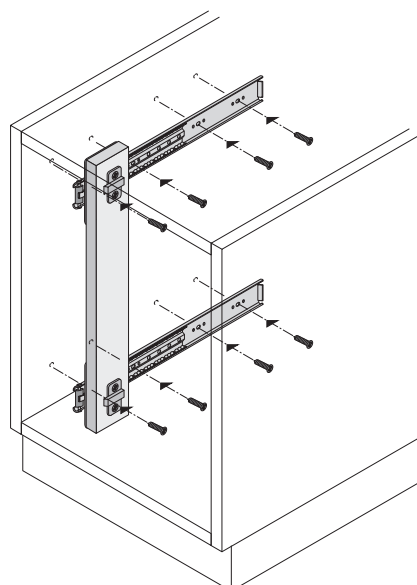

4

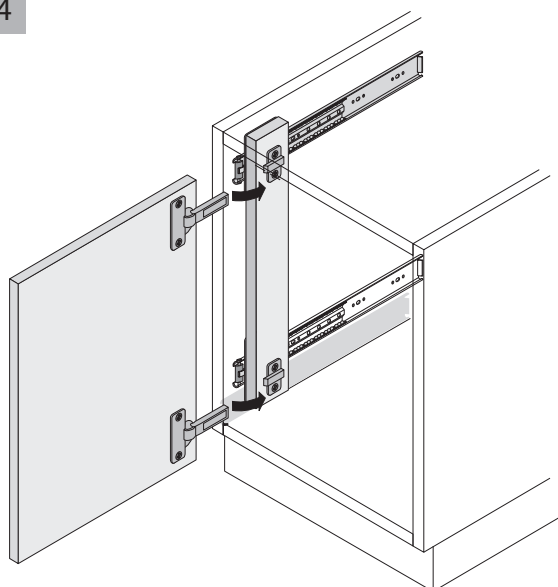

5

