

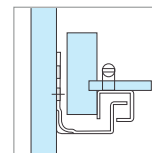

DTC

Glisieră Seria G02 A

Glisieră cu sistem PUSH și extragere parțială pentru sertare cu laterale din lemn

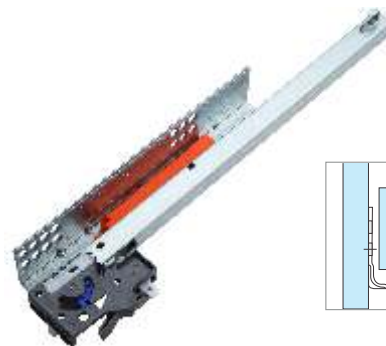

Cote de găurire, mm

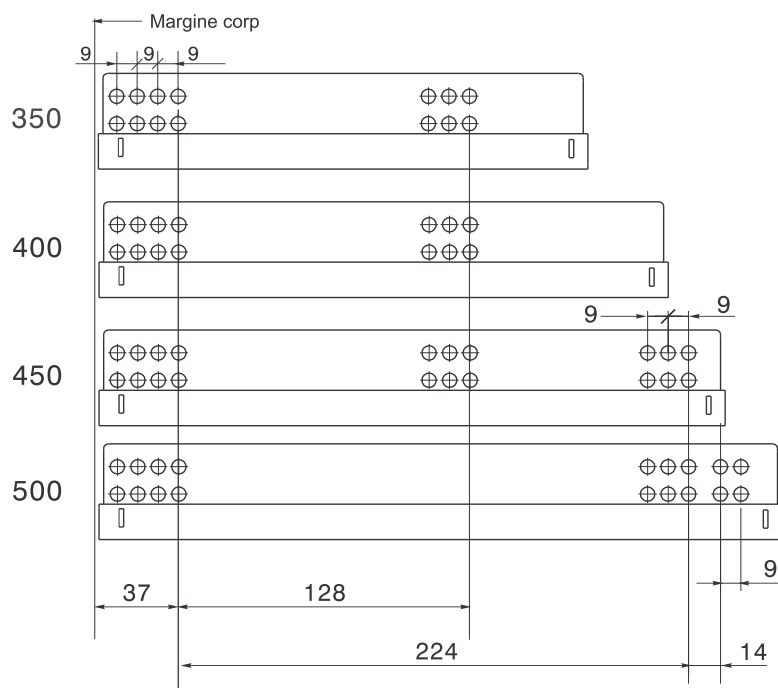

Cote de montaj, mm

SKW = Lățime internă sertar

LW = Lățime internă corp

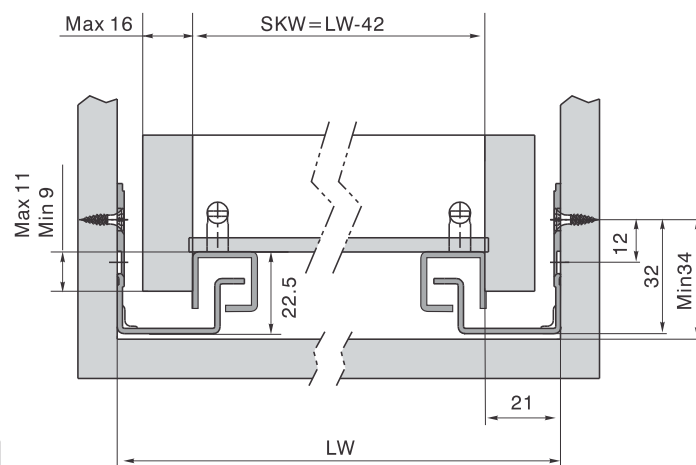

DTC

Glisieră Seria G02 A

Glisieră cu sistem PUSH și extragere parțială pentru sertare cu laterale din lemn

Cote de montaj

NL = Lungime nominală LT = Adâncime internă corp

Sertar interior
 $LT_{min} = NL + 21$

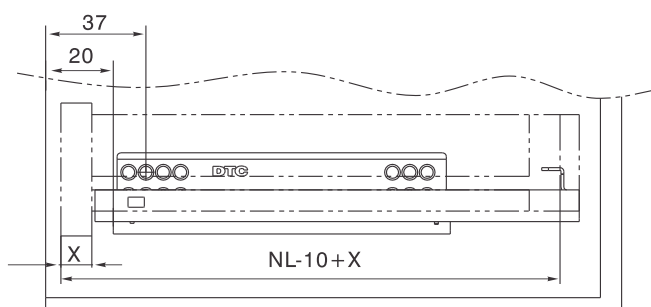

Cote de găurire

Sertar standard
 $LT_{min} = NL + 3$

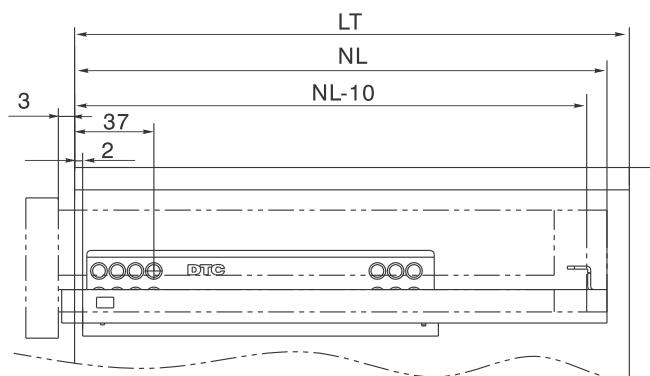

Extension loss

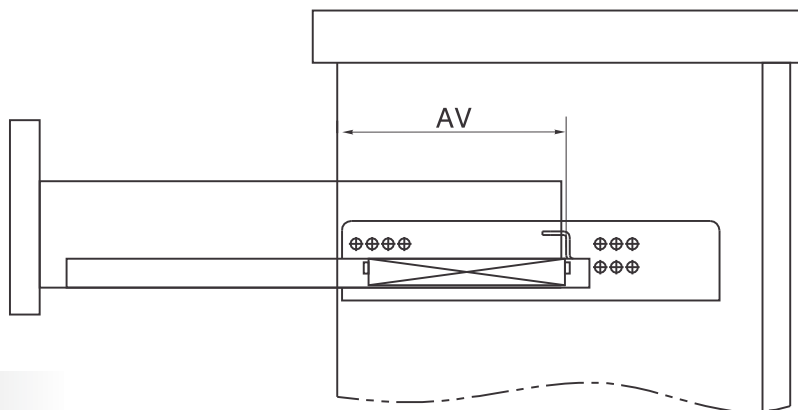

NL (mm)	350	400	450	500
AV (mm)	98.5	118.5	118.5	118.5

Cote sertar și de găurire

